

RV-3 STANDARD KIT ORDER FORM

1-1-09

Customer Number (assigned w/ emp kit)		
Name		
Mailing address		
Shipping address (if different)		
Day phone		
e-mail		
Fax		
Eve phone		

PLEASE READ AND SIGN BELOW

1. Kit prices are prices in effect the day order is received.
2. A 25% deposit must accompany kit orders.
3. Customer-instigated delays may result in price increases.
4. Kits must be paid in full before they can be shipped.
5. \$500.00 non-refundable if order is cancelled.
6. Payment in U.S. funds: check, money order, or Visa/Mastercard.
7. Kit/plans orders must be in writing (mail or FAX).
8. Prices are FOB Aurora, Oregon.
9. Freight charges payable on delivery.
10. Van's Aircraft, Inc. cannot assist in certifying kits outside the USA.
11. Prices are subject to change without notice.

Signature: _____

If you have completed, registered, and flown an RV, put customer number of completed aircraft here: _____

PREVIEW PLANS SET (required purchase before beginning construction)		\$45.00	
RVATOR SUBSCRIPTION Receive 6 printed issues of Van's company newsletter. On-line version available at no charge.	In USA,	\$15.00	
	outside USA,	\$20.00	
EMPENNAGE KIT		\$940.00	
Empennage Options (enter total from reverse side of form)			
WING KIT		\$5450.00	
Wing Options (enter total from reverse side of form)			
FUSELAGE KIT		\$2880.00	
Fuselage Options (from reverse side of form)			
FINISHING KIT If you are NOT taking advantage of Van's special OEM pricing on new Lycoming engines, and are obtaining an engine from another source, you must use the Special Finishing Kit order form. Use this form to order a Finishing Kit ONLY if you are purchasing a new engine from Van's.		\$4820.00	
Spinner type required (circle one)	Hartzell constant-speed	Sensenich fixed-pitch	Wood fixed-pitch
			None (\$120.00 credit)
Engine type	(I)O-320-D1A is the only suitable new engine available from Van's.		

TOTAL CRATING CHARGES		
TOTAL ORDER		
METHOD OF PAYMENT (if credit card, enter number/exp. date)		
AMOUNT ENCLOSED (25% minimum deposit required)		
Authorization to use Credit Card for Final Payment Yes No (circle one)		

VAN'S AIRCRAFT, INC.
 14401 NE Keil Road Aurora, Oregon USA 97002
(503) 678-6545 FAX (503) 678-6560
 ON THE WEB AT: www.vansaircraft.com e-mail: info@vansaircraft.com

OPTIONS

Choices and optional kits that are best installed during construction. Enter the amount for the option you are ordering in the box on the right.
Add the total for each airframe kit and enter that amount on the front of the form.

WINGTIPS AND RUDDER BOTTOMS ARE DESIGNED FOR LIGHTS. IF YOU ARE <u>NOT</u> INSTALLING LIGHTS CHECK THIS BOX:		
WING KIT		
FLOAT FUEL SENDING UNITS Arm with float senses fuel level. Works with Van's gauges and many other resistance gauges. Fits standard cover plates in wing kit. Includes gaskets. Two supplied -- one for each wing.	\$54.00	
QUICKBUILD WING: A huge time saver. The wing panel is about 80% completed at the factory. All parts primed before assembly. Fuel tanks finished, ailerons, flaps ready to install. Builder must rivet one wing skin, install wingtip, controls, fairings. Lights, fuel senders not included. NOTE that cost is <i>in addition</i> to Standard Wing Kit price.	\$3930.00	
TOTAL: ENTER ON FRONT OF FORM.		

FUSELAGE KIT		
STATIC AIR KIT: Includes static ports and lines to the instrument panel.	\$19.00	
MANUAL AILERON TRIM: Simple, light and effective spring bias system trims the roll axis. Inexpensive, too.	\$16.00	
TOTAL: ENTER ON FRONT OF FORM.		

Circle the crating charges that apply, total, and enter the amount on the front of the form.

CRATING CHARGES (these are NOT shipping charges)					
	Empennage	Wing	Qbuild Wing	Fuselage	Finishing
STANDARD	\$18.00	\$55.00	\$300.00	\$55.00	\$65.00
SEA FREIGHT	\$25.00	\$75.00	\$325.00	\$75.00	\$85.00
TOTAL: ENTER ON FRONT OF FORM.					

Name: _____ Date: _____ Customer number: _____

VAN'S AIRCRAFT, INC.
14401 NE Keil Road Aurora, Oregon USA 97002
(503) 678-6545 FAX (503) 678-6560
ON THE WEB AT: www.vansaircraft.com e-mail: info@vansaircraft.com

RV-3 SPECIAL FINISHING KIT ORDER FORM

Use when installing engines not supplied by Van's

1-1-09

Customer Number (assigned w/ emp kit)		
Name		
Mailing address		
Shipping address (if different)		
Day phone		
e-mail		
Fax		
Eve phone		

PLEASE READ AND SIGN BELOW

1. Kit prices are prices in effect the day order is received.
2. A 25% deposit must accompany kit orders.
3. Customer-instigated delays may result in price increases.
4. Kits must be paid in full before they can be shipped.
5. \$500.00 non-refundable if order is cancelled.
6. Payment in U.S. funds: check, money order, or Visa/Mastercard.
7. Kit/plans orders must be in writing (mail or FAX).
8. Prices are FOB Aurora, Oregon.
9. Freight charges payable on delivery.
10. Van's Aircraft, Inc. cannot assist in certifying kits outside the USA.
11. Prices are subject to change without notice.

Signature: _____

If you have completed, registered, and flown an RV, put customer number of completed aircraft here: _____

FINISHING KIT				\$4820.00		
Crating Charge (enter one)			Regular \$65.00, Sea Freight \$85.00			
DEFINING YOUR ENGINE						
<p>If you are using a new Lycoming from Van's use the regular Finish Kit Order Form. If you are using an engine from some other source, use this form. Van's engine mounts and cowls fit the engines we sell. NOTE THAT THE ONLY AVAILABLE RV-3 COWL IS DESIGNED FOR CARBURETED O-290/320 ENGINES. Other engine suppliers produce a wide variety of engines that may or may not correspond to Lycoming models.</p> <p>To provide us the information we need, you must complete the ENGINE IDENTIFICATION form on the reverse by circling the items that describe your engine. Without this information we cannot accept your order.</p> <p>If you are installing an engine that is not compatible with Lycoming style mounts or cowl, you may delete these items for credit. The exact amount of the credit will be determined by Van's.</p> <p>It is the customer's responsibility to provide accurate information. Van's Aircraft, Inc. is not responsible for costs incurred replacing or returning incorrectly ordered parts.</p>						
ENGINE MOUNT		Use data sheet on opposite side		None		
COWL TYPE		Use data sheet on opposite side		None		
SPINNER TYPE NOTE: if supplying own spinner or buying new MT prop (supplied with spinner) -circle none.		Hartzell constant-speed	Sensenich fixed-pitch	Wood fixed-pitch	None (\$120.00 credit)	
TOTAL ORDER						
METHOD OF PAYMENT (if credit card, enter number/exp. date)						
AMOUNT ENCLOSED (25% minimum deposit required)						
Authorization to use Credit Card for Final Payment Yes No (circle one)						

VAN'S AIRCRAFT, INC.

14401 NE Keil Road Aurora, Oregon USA 97002
(503) 678-6545 FAX (503) 678-6560

ON THE WEB AT: www.vansaircraft.com e-mail: info@vansaircraft.com

ENGINE IDENTIFICATION

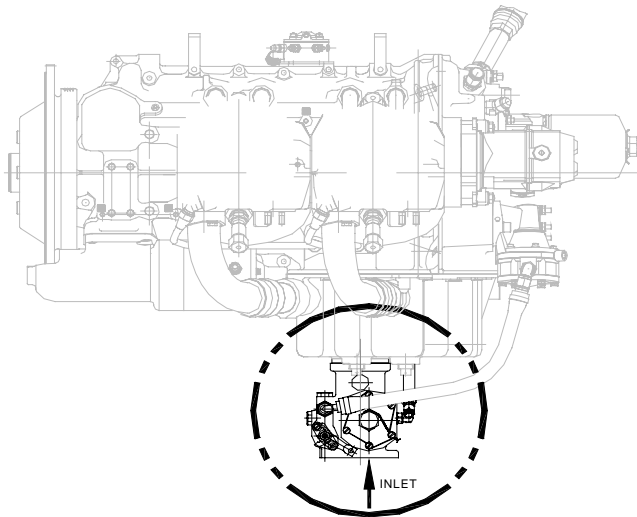

VERTICAL INDUCTION

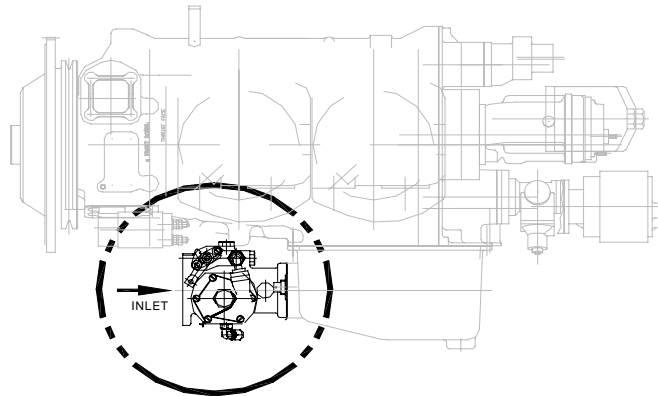

HORIZONTAL INDUCTION

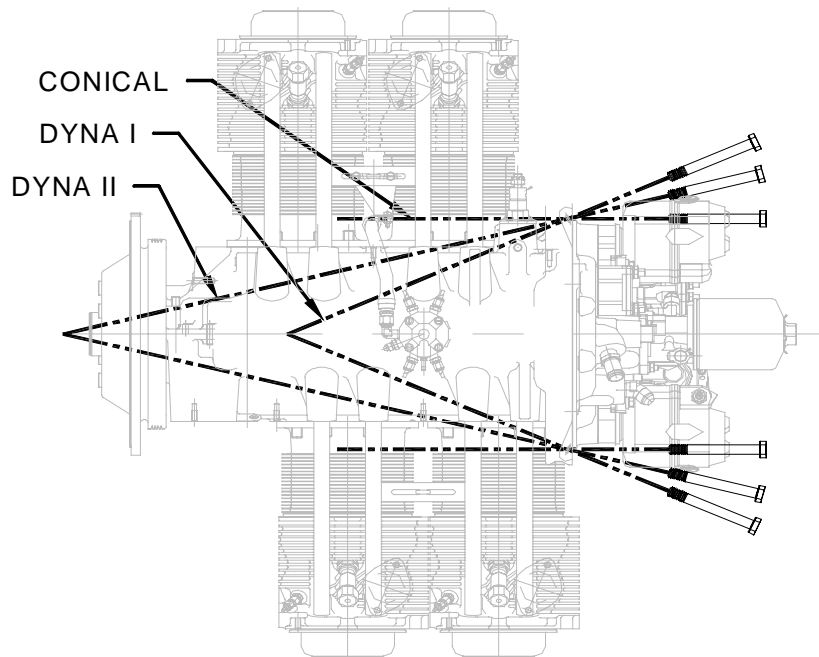

ENGINE MOUNT STYLE

VALVE COVER SHAPE

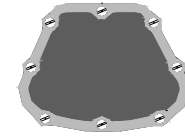

ANGLE VALVE

EXAMPLE:
IO-360 A1B6 (200 HP)

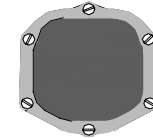

PARALLEL VALVE

EXAMPLE:
I(O)-320 D1A (150 - 160 HP)
I(O)-360 A1A (180 HP)

ENGINE STYLE

(PLEASE CIRCLE ONE FOR EACH CATEGORY)

INDUCTION: *VERTICAL OR HORIZONTAL*

CYLINDER TYPE: *PARALLEL VALVE OR ANGLE VALVE*

DISPLACEMENT: *235 OR 290 OR 320 OR 360 OR 540*

MOUNT STYLE: *DYNAFOCAL I OR DYNAFOCAL II OR CONICAL*

FUEL METERING: *FUEL INJECTED OR CARBURETTED*

ENGINE SUPPLIER: *AERO SPORT POWER OR SUPERIOR OR
MATTITUCK OR LYCOMING*

OTHER _____

CUSTOMER NAME: _____

CUSTOMER NUMBER: _____